



INDUSTRIAL VALVE SOLUTION



Grupa Baltina

[www.mixflow.com.pl](http://www.mixflow.com.pl)

PL 80 – 067 Gdańsk,  
ul. Równa 19/21

Tel: +48 58 676 55 39

[elektrogas@mixflow.com.pl](mailto:elektrogas@mixflow.com.pl)



Autoryzowany Przedstawiciel marki:  **elektrogas**<sup>®</sup>



**TR**

**Ignition transformer**

# TR Ignition transformer

## Table of contents

Description.....	2
Features .....	2
Technical specification .....	3
Identificazione .....	5
Ordering Information .....	4
Standards and approvals .....	4

## Description

Ignition transformers TR are suitable for high-voltage spark ignition of gas burners.

The range is composed by:

- models with different ED: compact models for lighter sparks or unfrequent ignition and larger models for stronger sparks or frequent ignition (e.g. pulse firing);
- models with inductive design (TRE and TRS) and models with electronic working (TRK);

TR are suitable for double or single rod operation (ignition and flame detection with the same rod, switchover between ignition and flame detection has to be performed by the burner control unit).

They shall be installed in a control cabinet or can be supplied in a metallic box IP65 easy to be installed near the burner.

Figure below show and example of application of TR with other Elektrogas devices.

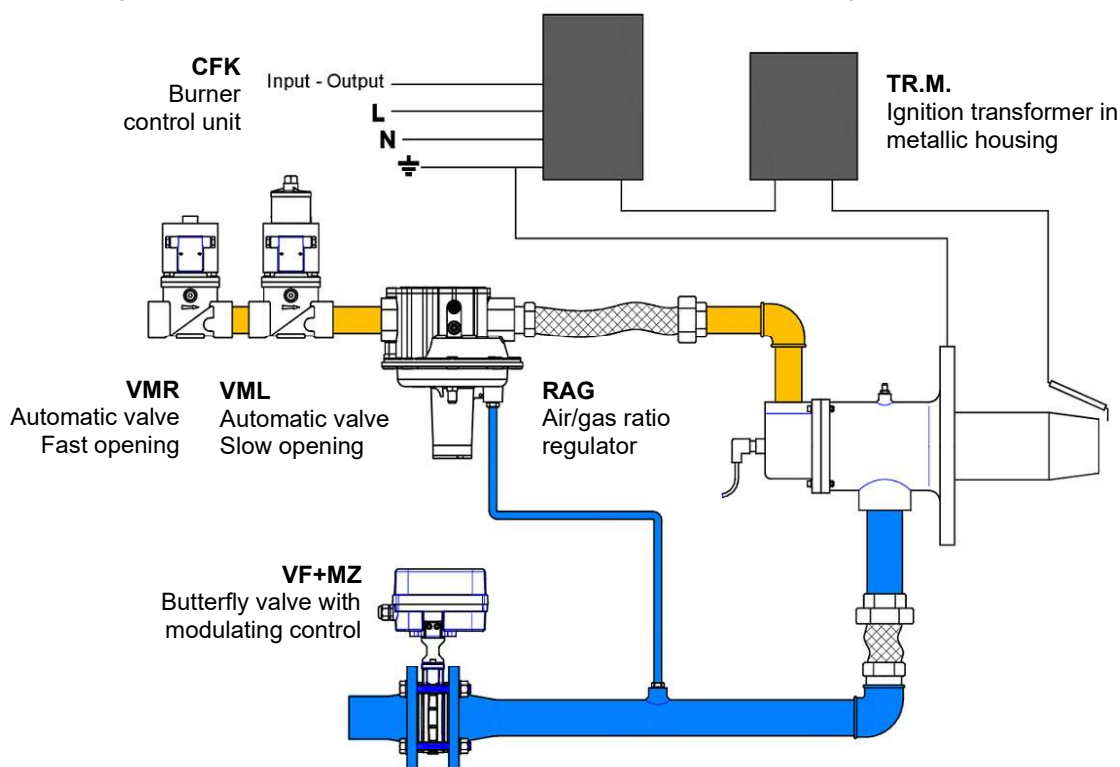

Fig. 1



### WARNING

This device must be installed in compliance with the rules in force.

## Features

### TRE and TRS are inductive transformers with:

Tab. 1

<b>Primary Supply Voltage</b>	230 V 50/60Hz 115 V 50/60Hz
<b>Primary connection</b>	Cable 380 mm
<b>Hi Voltage Outlet</b>	Self-tapping screw (15 mm deep) for cable with external diameter Ø8 max
<b>Ambient temperature</b>	-20/+60°C <small>note 1</small>
<b>Protection grade (EN60529)</b>	IP00
<b>Ignition cable length</b>	< 5 m <small>note 2</small>
<b>Spark gap</b>	3..5 mm
<b>Mounting position</b>	ANY <small>note 3</small>

Models	TR			
	E.C	E.I	S.C	S.I
<b>Power</b>	70VA	230VA	150 VA	230 VA
<b>Secondary Voltage</b> (open circuit ±10% RMS)	5 kV	8 kV	8 kV	8 kV
<b>Secondary Current</b> (short circuit)	10 mA	20 mA	12mA	20 mA
<b>Duty cycle</b> (3 minutes - temperature -20 / +35°C)	100%	19%	100%	25%
<b>Weight</b>	1,35 Kg	1,35 Kg	1,95 Kg	1,95 Kg

#### Notes:

- 1- operating temperature higher than 35°C can reduce the operating life of the device
- 2- in case of single-rod operation, cable length must be as short as possible.
- 3- with enough space for free air ventilation

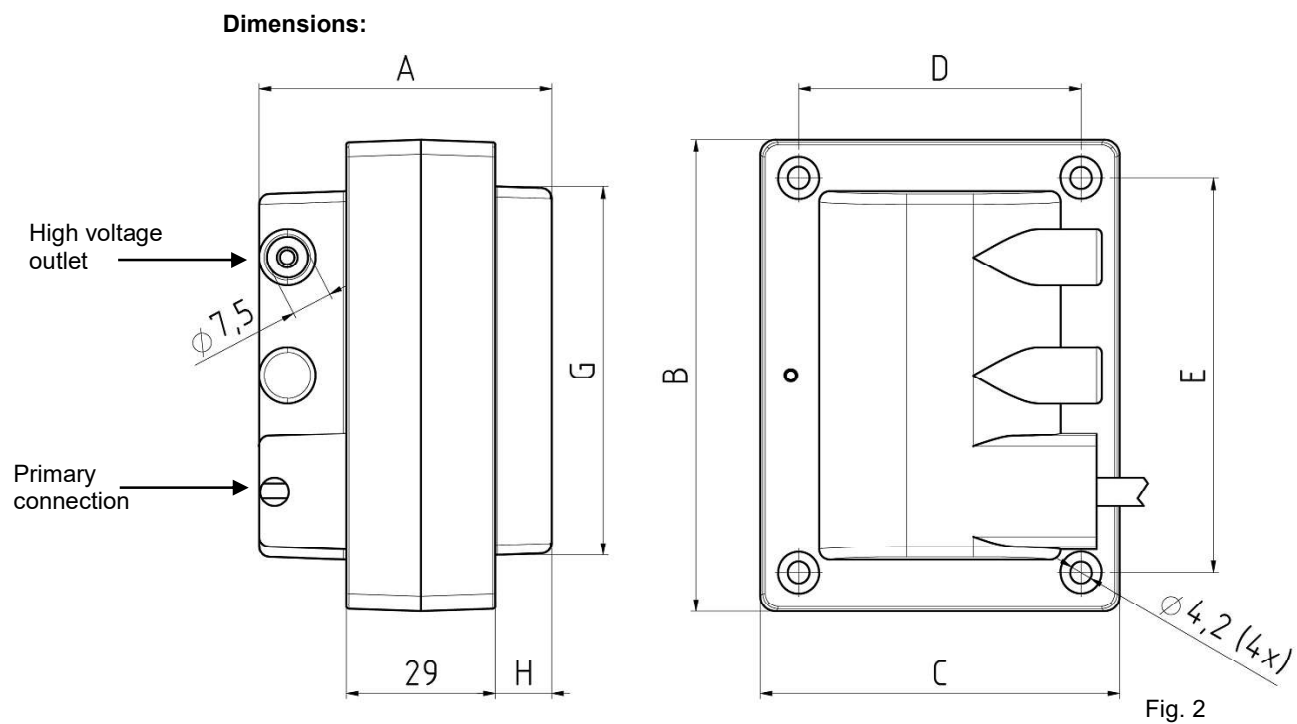

	Dimensions (mm)						
Models	A	B	C	D	E	G	H
TRE.C TRE.I	57	92	70	55	77	72	11
TRS.C TRS.I	65	107	86	70	90	87	15

**TRK is an electronic transformer:**

Tab. 2

<b>Primary Supply Voltage</b>	230 V 50/60Hz 115 V 50/60Hz
<b>Primary connection</b>	Plug with cable 2poles+PE 380 mm (supplied with the transformer)
<b>Power</b>	70 VA
<b>Secondary Voltage</b>	15 kV ±10% (open circuit)
<b>Secondary Current</b>	30 mA RMS (short circuit) Min 20 mA RMS (5 mm spark gap, blowing air)
<b>Hi Voltage Outlet</b>	Vertical pin Ø 4 mm (13,5 mm deep) for cable with external diameter Ø8 max
<b>Duty cycle</b>	33% (3 minutes for temperature -20 / +35°C)
<b>Ambient temperature</b>	-20/+60°C <small>note 1</small>
<b>Protection grade (EN60529)</b>	IP00
<b>Ignition cable length</b>	< 5 m <small>note 2</small>
<b>Spark gap</b>	3..5 mm
<b>Mounting position</b>	ANY <small>note 3</small>
<b>Weight</b>	0,34 Kg

Notes

- 1- operating temperature higher than 35°C can reduce the operating life of the device.
- 2- in case of single-rod operation, cable length must be as short as possible.
- 3- with enough space for free air ventilation.

**Dimensions:**

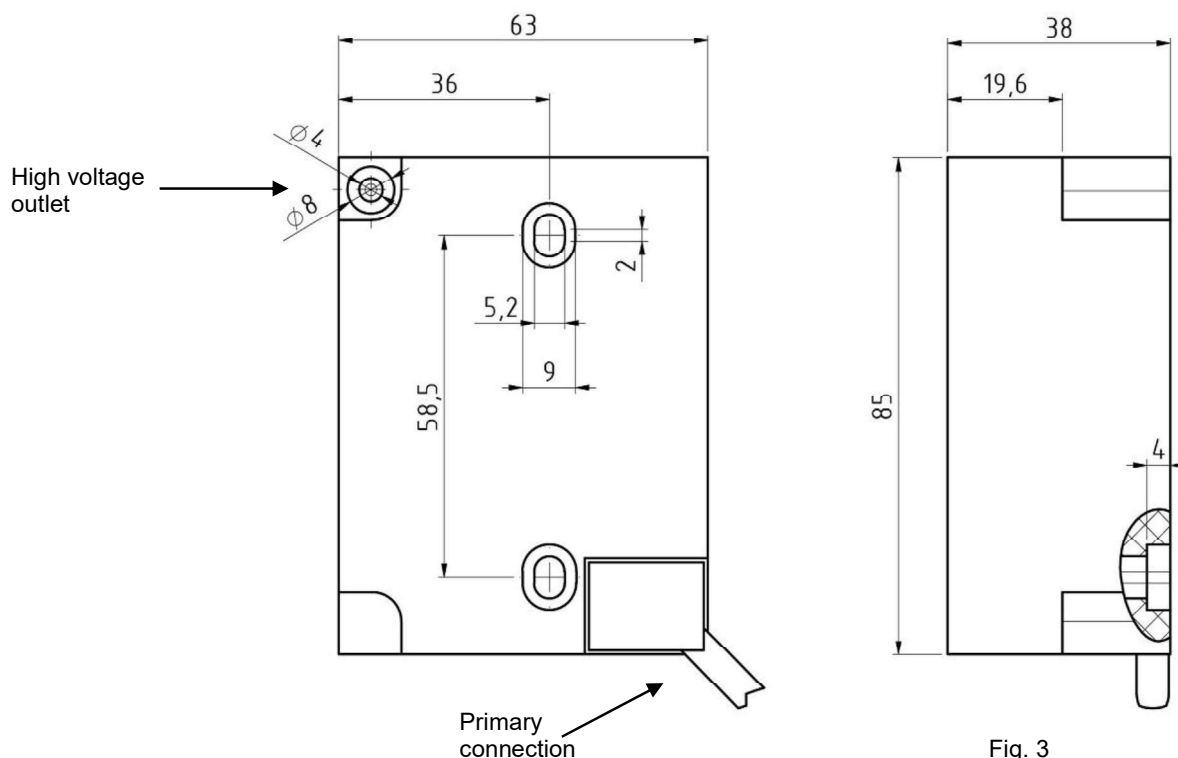

**Wiring:**

- use suitable cables (ambient temperature, working voltage...);
  - use unscreened high-voltage cable as ignition cable (spark intensity is lower in case of screened cable);
  - do not use metallic conduit for ignition cable;
  - keep the ignition cable as short as possible (the longer the ignition cable, the lower the spark intensity and greater the generated electrical interferences);
  - keep ignition and ionization cables separate;
  - if necessary, to reduce radio interferences, use plugs with integrated filter;
  - provide a reliable ground connection between transformer and burner frame (recommended wire gauge > 4 mm<sup>2</sup>).
- table below shows wiring of TRE, TRS and and TRK with CFK burner control:

Tab. 3

	1 shared / single rod	2 independent / double rods
TRE TRS		
TRK		

**TR.M is a connection box with a TRE or TRS transformer inside:**

<b>Materials</b>	Aluminum grey painted
<b>Protection grade (EN60529)</b>	IP65
<b>Slot on external walls</b>	Ø6
<b>Inlet-Outlet</b>	2 cable glands for cable Ø min 4 max 8 – threads Pg9

**Dimensions:**

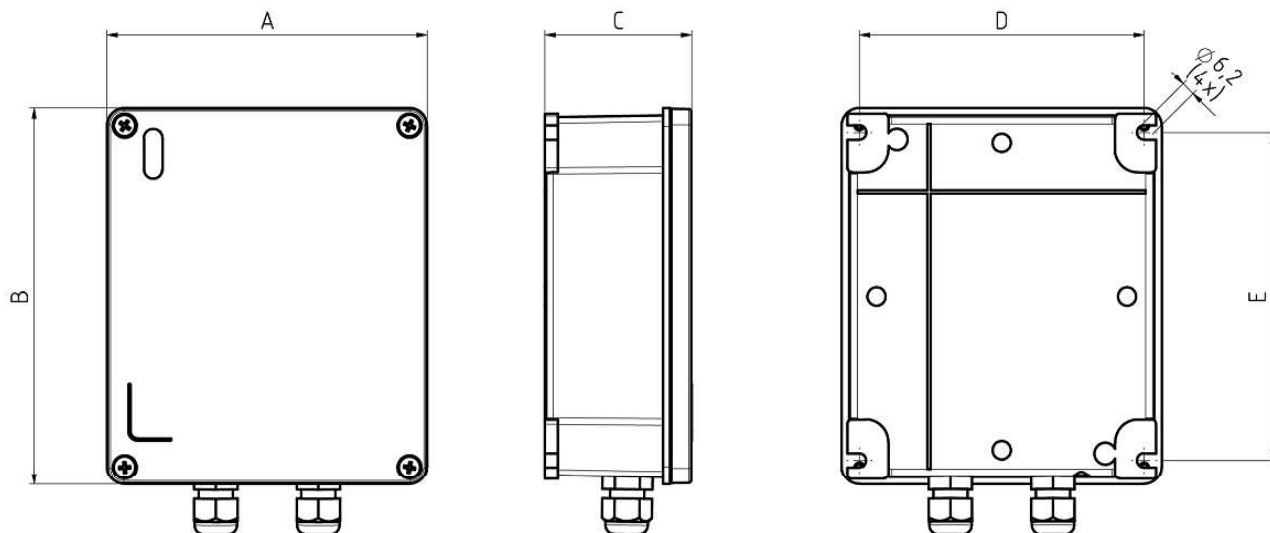

Fig. 4

Models	Dimensions (mm)					Weight (Kg)
	A	B	C	D	E	
<b>TRE..M.</b>	141	166	65	125	144	2,1
<b>TRS..M.</b>	167	190	80	149	168	2,9

**Internal layout:**

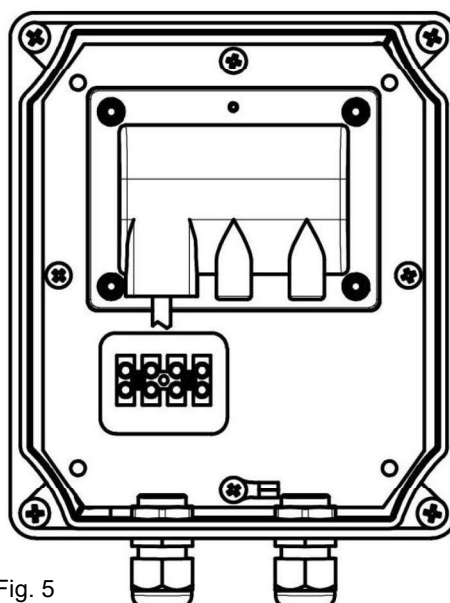

Fig. 5

## Ordering Information

Tab. 4

	TR	E.I	A
<b>Product</b>			
<b>TR</b>	Ignition transformer		
<b>Type</b>			
<b>E.C</b>	Inductive 5KV 10mA ED 100%		
<b>E.I</b>	Inductive 8KV 20mA ED 19%		
<b>S.C</b>	Inductive 8KV 12mA ED 100%		
<b>S.I</b>	Inductive 8KV 20ma ED 25%		
<b>K.I</b>	Electronic 15KV 30mA ED 33%		
<b>Cover (optional)</b>			
<b>_</b>	without cover		
<b>M</b>	aluminum cover ( <u>only TRE and TRS</u> )		
<b>Voltage</b>			
<b>A</b>	230 V AC		
<b>B</b>	115 V AC		

## Standards

TR transformers are designed and manufactured in accordance with:

- Directive 2014/35/EU (LVD) on the basis of norm EN61558-2-3 and EN60730-2-5.
- Directive 2014/30/EU (EMC) on the basis of norm EN 61000-3-2 and 3.

Especially for EMC conformity, system manufacturer has to consider that high-voltage arcs may cause radio interference and has to provide evidence of compliance with applicable legislation, if necessary suitable filters has to be installed.

Quality management system certified in accordance with EN ISO 9001.



PL 80 – 067 Gdańsk,  
ul. Równa 19/21  
Tel: +48 58 676 55 39  
[elektrogas@mixflow.com.pl](mailto:elektrogas@mixflow.com.pl)



Autoryzowany Przedstawiciel marki:  **elektrogas**<sup>®</sup>

The information in this document contains general descriptions of technical options available and based on current specifications.  
ELETTROMECCANICA DELTA S.p.A. reserves the right to update or make any technical changes without prior notice.

Elektrogas is a trademark of:  
Elettromeccanica Delta S.p.A.  
Via Trieste 132  
31030 Arcade (TV) – ITALY  
tel +39 0422 874068  
fax +39 0422 874048

[www.delta-elektrogas.com](http://www.delta-elektrogas.com)  
[info@delta-elektrogas.com](mailto:info@delta-elektrogas.com)

Copyright © 2022  
Tutti i diritti riservati